

Single-phase AC multi-parameter digital transducer manual

CE-AJ1*-*****-0.5

1 Overview

This product is a power integrated measurement of single-phase digital isolation transducer. It can measure the full-parameter of the AC circuit. Using high-precision 24-bit dedicated AD chip, the ratio dynamic range can be up to 1000: 1, the measurement parameters are voltage, current, frequency, active power, reactive power, power factor, total accumulative energy and other electrical parameters with high accuracy, good stability and high communication speed, the completely isolated processing technology is with anti-interference ability. Measurement of electrical parameters through the RS-485 digital interface output to achieve long-distance transmission, the product MODBUS protocol is complete compatible with a variety of configuration software or PLC equipment MODBUS (RTU) protocol. It can be applied to power, room monitoring, industrial measurement and other fields

2 Part Number

CE-A product selection is as follows, in order to make your selected products accurate application, please read carefully.

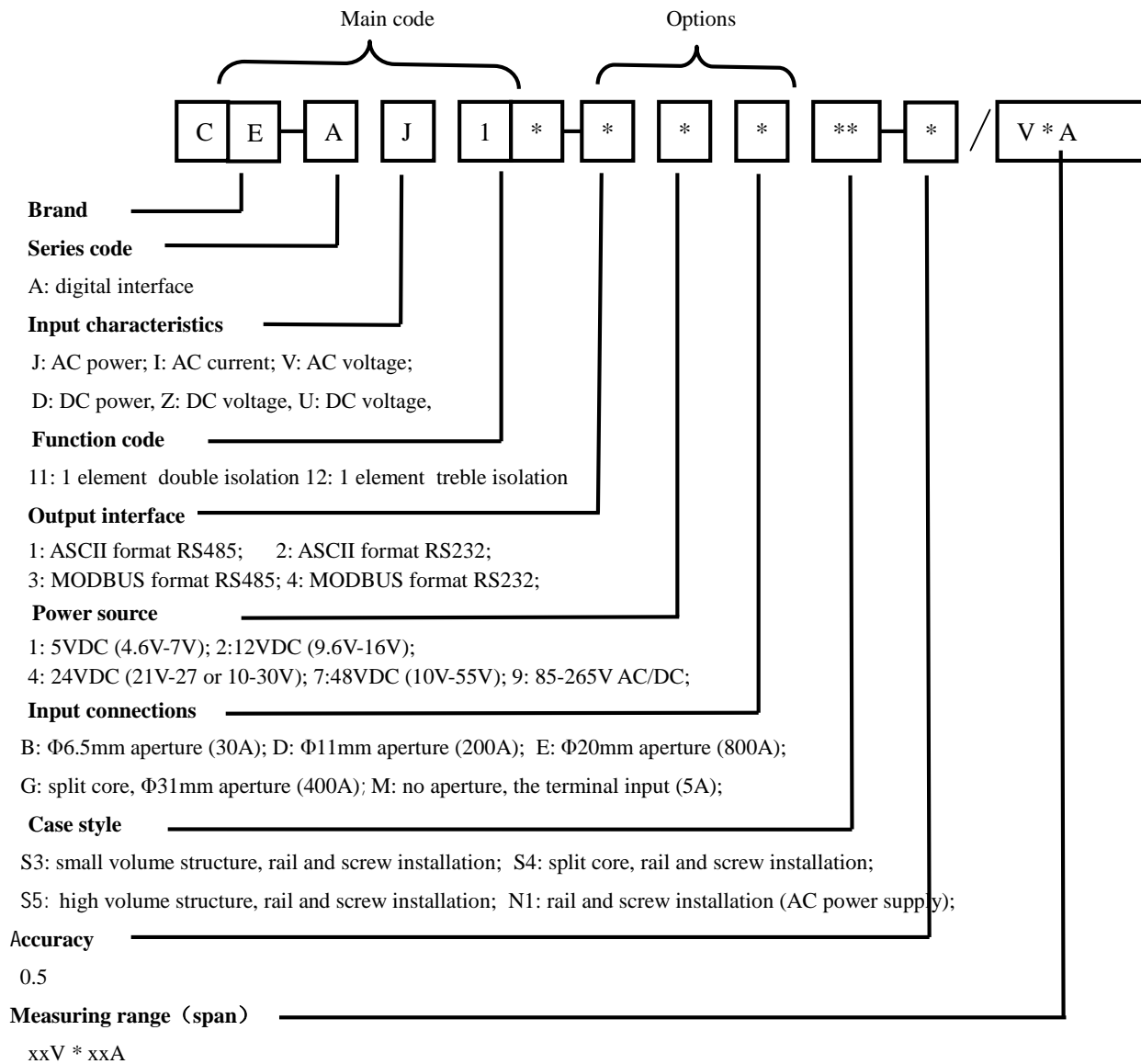

3 Product Features

- 2 Available with wide power supply: DC: 10-30V or 10-55V
- 2 With odd parity, even parity, no parity, 2 stop bits and other communication methods are free to set.
- 2 Communication speed optional, the maximum communication speed to 115200 bps.

- 2 The intelligent transducer with the smallest size and wide current measurement range in the peer
- 2 Electroplating has a positive and negative cumulative, and power-down storage function.
- 2 With red and green light-emitting diode instructions function, the red light indicates the normal operation of the product (100ms flashing), the green light indicates the product communication.
- 2 High anti-interference ability, the input, output and power port to resist the surge voltage up to 2KV or more.

4 Specifications

NO,	Item	Date	Unite	Remarks
1	Accuracy	0.2,0.5	%	0.2 for voltage and current value only
	Input range	S3 case:500V*30A; S4 case:500V*500A; ES5 case:500V*700A; N1 case:500V*5A; DS5 case: 500V*200A		The maximum range for each specification
	Frequency	Frequency response: 20Hz-1KHz; Frequency measurement: 20-600Hz		
2	Baud rate	115.2K, 57.6K, 38.4K, 19.2K, 9600(default) 4800, 2400, 1200	bps	Factory default communication format: 9600, N/8/1, address 1; S5 type up to 19.2K;
	Communication	RS-485(twisted pair line) , RS-232C(treble line, only for N style parts)		RS422 optional
	Parity	None, Even, Odd, Space		
	Max. number of nodes	64	Node	Only for RS-485
	Bus protection	400W transient voltage		ESD protection and thermosnap
3	A/D SPEED	100	mS	
4	Working temperature	-20℃~+60℃		
5	Isolation voltage	Input/output: 2500V DC for 1 min Input/power supply: 2500V for 1 min Output/power supply: 2500V for 1 min	V	The double isolation part numbers, their output and power supply are grounded together, there is only between the input and output isolation voltage
6	Overload	2 x voltage span 1 sec. 10 for times with interval of 10 sec. 10 x current span for 1 sec. 5 times with an interval of 300 sec (only for hole thru. parts)		The input outside the linear range will result in poor accuracy
7	MTBF	>30000	hour	
8	Auxiliary power supply	+5V/+12V/+24V/+48V/ AC220V	V	220VAC,DC only for N case parts
9	Power consumption	≤250mW(+12V), ≤500mW(+24V)	mW	Power consumption depends on power supply to be used
10	Temperature drift	≤300	ppm/℃	(-20℃~+60℃)

5 Case Style (marked in the figure Unit: mm)



Figure 5.1 CE-AJ1*-*BS3 type product shape

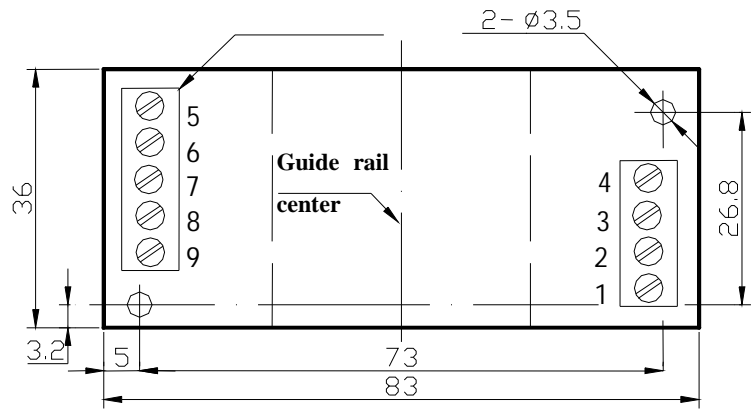

Figure 5.2 CE-AJ1*-*BS3 product installation diagram



Figure 5.3 CE-AJ1*-*MN1 type product shape(220VAC power supply)

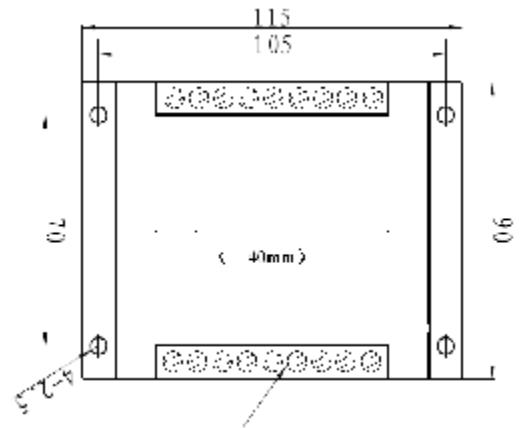

Figure 5.4 CE-AJ1*-*MN1 product installation diagram

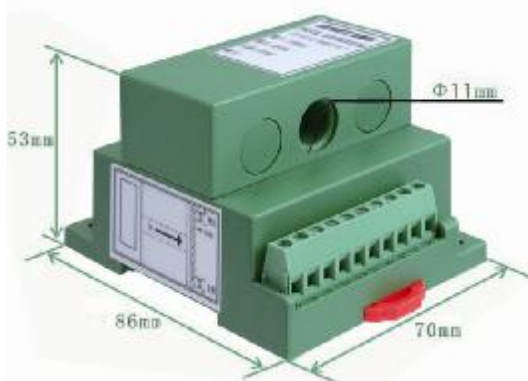

Figure 5.5 CE-AJ1*-*DS5 type product shape

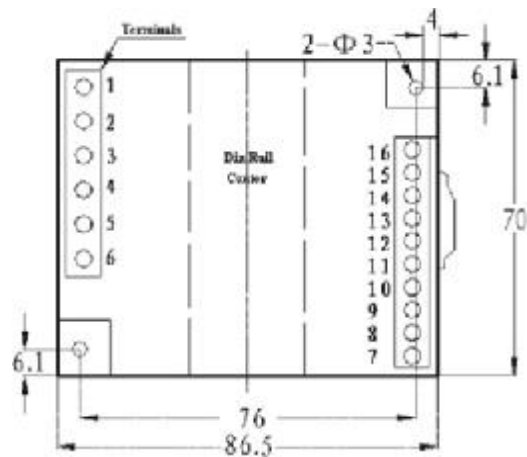

Figure 5.6 CE-AJ1*-*DS5 product installation diagram



Figure 5.7 CE-AJ1*-**ES5 type product shape

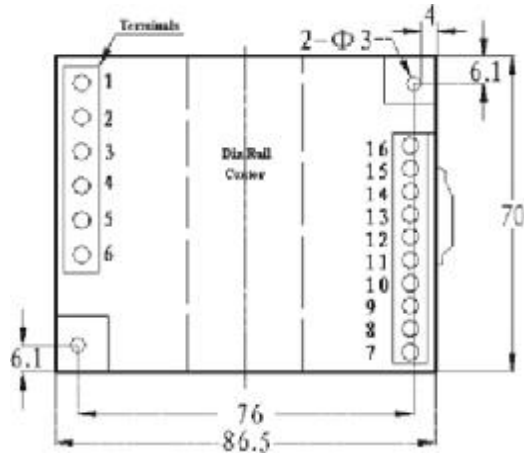

Figure 5.8 CE-AJ1*-**ES5 product installation diagram

6 Terminal definition and connection diagrams

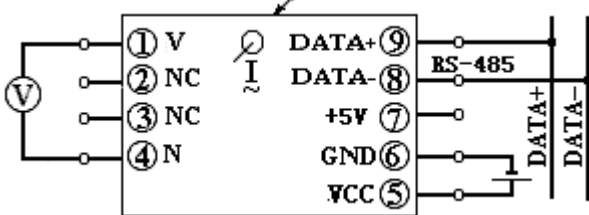

Figure 6.1 Single-phase CE-AJ11-**BS3 wiring diagram

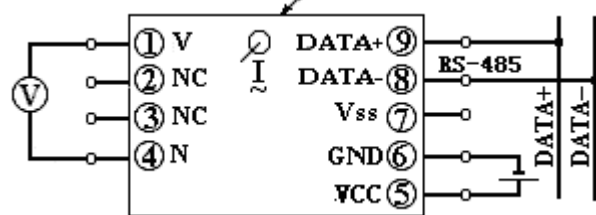

Figure 6.2 Single-phase CE-AJ12-**BS3 wiring diagram

(Terminal 7 output is +5 V to provide 5V output (<20mA), figure 6.2 terminal 7 Vss for the 485 output.

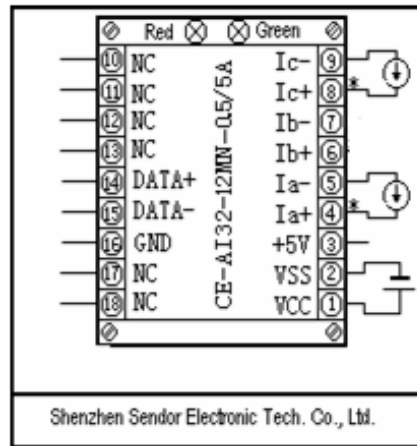
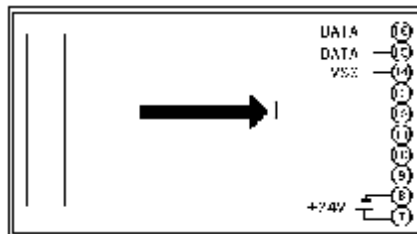

Figure 6.3 Single-phase CE-AJ12-**MN1 Product Wiring Reference Drawing

Refer to Figure 6.3 for the single-phase current wiring diagram of S5Wiring Reference Drawing



7 ASCII command set for single-phase digital isolation transducer

There are six ASCII format commands for communications between master and CE-A transducer, in addition there are four internal commands as follows:

- I To read the transducer's name: \$(Addr)M<CR>
- I To read the configuration: \$(Addr)2<CR>

- I To set the configuration: %(OldAddr)(NewAddr)(InpntRange)(BaudRate)(DataFormat)<CR>
- I To read all date: #(Addr) A<CR>
- I To read the positive accumulative energy: #(Addr)W<CR>
- I To read the negative accumulative energy: #(Addr)X<CR>
- I To clear the data of energy: &(Addr)(Order)<CR>

Address (Addr): 00~FF (hex indicated by two bit ASCII code)

Data format: 1 bit for start bit "0", 8 bits for data, 1 bit for stop bit "1"

1 To read the transducer's name

To read the transducer's name from a specified address.

Command format: \$ (Addr) M<CR>

\$:	Command symbol	1byte	(24H)
(Addr):	Address	2 bytes	(30H 31H)
M:	To read the transducer's name	1byte	(4DH)
<CR>:	Enter, end mark	1byte	(0DH)

Response: ! (Addr) (ModuleName) <CR>

! :	Delimiter
(Addr):	Address of the transducer
Module Name:	Name code of the transducer
<CR>:	Enter, end mark

Example: command: \$01M<CR> (24H 30H 31H 4DH 0DH)

Response: 01J112<CR> (21H 30H 31H 4AH 31H 31H 32H 0DH)

! : Delimiter

01: Address

J112: CE-AJ11-12 the name code of the transducer

2To read the configuration

To read the configuration of a transducer by a specified address

Command format: \$ (Addr) 2 <CR>

\$:	Command symbol	1byte	(24H)
(Addr):	Address of the transducer	2bytes	(30H 31)
2::	To read the configuration	1byte	(32H)
<CR>:	Enter, end mark	1byte	(0DH)

Response: ! (Addr) (InputRange) (BaudRate) (DataFormat) <CR>

Example: Command: \$012<CR> (21H 30H 31H 32H 0DH)

Response: ! 01000601 <CR>

!	(21H)	Delimiter
01	(30H 31H)	Address
00	(30H 30H)	Input range (reserved codes)
06	(30H 36H)	Communication Baudrate 9600bps
01	(30H 31H)	No checksum
<CR>	(0DH)	End mark

3To set configuration

To set the configuration of the transducer including address and baudrate

Command: % (OldAddr) (NewAddr) (InputRange) (BaudRate) (DataFormat) <CR>

%	Command symbol	1byte	(25H)
(OldAddr)	Old address 00~FFH	2bytes	(30H 31H)
(NewAddr)	New address 00~FFH	2bytes	(30H 32H)

(InputRange) Must be 00 2bytes (30H 30H)

(BaudRate) The communication baudrate 03~0A 2bytes (30H 33H----30H 41H)

NO.	Baudrate code	baudrate	NO.	Baudrate code	baudrate
03	30H 33H	1200bps	07	30H 37H	19200bps
04	30H 34H	2400bps	08	30H 38H	38400bps
05	30H 35H	4800bps	09	30H 39H	57600bps
06	30H 36H	9600bps	0A	30H 41H	115200bps

(DataFormat) 01~05 2bytes (30H 31H----30H 35H)

NO.	Baudrate code	Data Format
01	30H 31H	No parity
02	30H 32H	Odd parity
03	30H 33H	Even parity
04	30H 34H	2stop bits, must be 1
05	30H 35H	2stop bits, must be 0

<CR> Enter, end mark

Response: ! (Addr) <CR>

or

? (Addr) <CR>

Example :command: %0102000701 <CR> (25H 30H 31H 30H 32H 30H 30H 30H 37H 30H 31H 0DH)

Response: ! 02 <CR> (21H 30H 32H 0DH)

This command successfully changed the address of the transducer from 01 to 02, its new baudrate is 19200bps

4 To read all data

To read all real-time data from a specified transducer. The sequence of data is: U、I、P、Q、COSΦ、F

Command: # (Addr) A<CR> (23H 30H 31H 41H 0DH) Assume the address is 01

Response: >(Data U) (Data I) (Data P) (Data Q) (Data COSΦ) (Data F) <CR>

Data XX: the data consist of a sign "+"or "-", and 5 decimal value of data and decimal point.

The value is a percentage of the nominal full scale.

Data F: the data F consist of 5 digits og decimal value and the decimal point. This value is a real value of the frequency measured

Data COSΦ: the data consist of a sign "+"or "-", and 5 digits of decimal value of data and a decimal point. This value is a real value of the power factors measured

For example: I nominal range is 5A; If the output data is +0.6000, the actual value is $I=+0.6000 \times 5A=+3.0000A$

Example: suppose the maximum value of its measurable range: current $I_0=5A$, voltage $U_0=100V$, frequency 50Hz

Command: #01A<CR> (23H 30H 31H 41H 0DH)

Response: >+1.0000+0.6000+1.0000+0.6000+1.0000+0.6000+0.6000+0.0000+1.000050.000<CR>

Then: $U=+1.0000 \times U_0=+1.0000 \times 100V=100.00V$

$I=+0.6000 \times I_0=+0.6000 \times 5A=3.0000A$

$P=+0.6000 \times U_0 \times I_0=+0.6000 \times 100V \times 5A=+300.00W$

$Q=+0.0000 \times U_0 \times I_0=+0.0000 \times 100V \times 5A=0Var$

$COS\Phi=+1.0000$

$F=50.000Hz$

5 to read the positive and negative data of total accumulative energy

5.1 to read the command of positive and negative energy: # (Addr) X<CR>

Response: >(Order)(+) (Data Kwh) (+) (Data Kvarh) (-) (Data Kwh) (-) (Data Kvarh) (CHK) <CR>

5.2 to read the command of positive energy: # (Addr) W<CR>

Response: > (Order) (+) (Data Kwh) (+) (Data Kvarh) (CHK) <CR>

# :	command symbol	(23H)	1byte
W:	to read the data of energy	(57H)	1byte
(Order):	frame number	00~FF	2 byte
(+) :	sign + or -	2BH or 2DH	1 byte
(Data):	hexadecimal ASCII data		6 bytes
(CHK):	checksum (hex)		2 bytes

The intelligent transducer can output the total accumulative active energy and reactive energy. It starts to accumulate immediately after power on. The data of total accumulative energy are stored in the ferroelectric RAM of the transducer. The transducer will respond the data of energy immediately after received the command to read that data of total accumulative energy.

The format of response is an follow:

>	(Order) (+) (Data +Kwh) (+) (Data -Kwh) (CHK) <CR>		
>:	response symbol (3EH)	1byte	
(Order):	frame number(from 00to FFH)	2 bytes	hex ASCII(see note 1)
(+) :	sign + or -	1byte	hex ASCII
(data +Kwh) :	data of active energy	6 bytes	hex data
(+) :	sign + or -	1byte	hex ASCII
(data -Kwh) :	data of reactive energy	6 bytes	hex data
(CHK) :	checksum	2 bytes	accumulating 17 bytes given before(CHK)

Then the sum is ANDed with OFFH to get the 2 bytes og hex data

Note1: Each response of the accumulative total active energy and reactive energy data has a frame number. When the transducer is powered on, its frame number starts with zero. When the transducer receives a correct command to clear the data of energy from master equipment, the transducer clears the energy data in its ferroelectric RAM and adds 1 to the frame number(circulating 00 through FF). The output data of energy are the sum of last output plus the new accumulated energy since the last output. If the transducer did not receive the correct command to clear energy data, the frame number will not change, and the data of the energy will not be cleared and the transducer will continue to accumulate.

Generally, the data of the energy starts to accumulate from zero immediately after the transducer is turned on. The longest period to accumulate is 1533.4 hours when U and I of the input reach the maximum value of measuring range. The data will overflow when this value is exceeded. For the part numbers with accumulative energy data power failure protection function, they can save the accumulated active and reactive energy data when power is removed, and when power is reconnected to the transducer, the transducer begins accumulating energy from where it left off when power was removed.

Calculating of energy (the U_0 and I_0 is the maximum value of measurable range of the transducer)

$$\text{Energy} = \pm \text{DATAN} \times \frac{U_0 \times I_0}{1000 \times 3600} \text{ kwh}$$

Example: command: #01W<CR>

Response: >01-0003E800003A68<CR> (hex)

The frame number is: 01

Active energy: -3E8H (hex) or 1000(decimal)

Reactive energy: 3AH (hex) or 58 (decimal)

Checksum: 68=(0x3E+0x30+0x31+0x2D+0x30+0x30+0x30+0x33+0x45+0x38+0x2B+0x30+0x30+0x30+0x33+0x41)

MOD 0x100

6 To clear the data of energy

Command: &(Addr) (Order) <CR>

Response: !(Addr)<CR> (21H 30H 31H 0DH)

Or: ?(Addr)<CR> (response to a wrong received)

Example: command: &0101<CR>

Response: !01<CR> (response to command with a correct frame number)

Or ? 01<CR> (response to command with a wrong frame number)

7 Internal commands

A group of internal calibrating commands was set for calibration of the CE-AJ product: (Note: the second byte and the third byte of following four commands are address codes of transducer, the default address codes of all transducers were set to "01" before they are delivered.

Command format &(Addr) (Order) <CR>

I Calibrating command of zero adjusting for DC: \$011<CR> (24H 30H 31H 31H 0DH)

I Calibrating command of zero adjusting for AC: \$013<CR> (24H 30H 31H 33H 0DH)

For above two commands, each returns 22 bytes of data.

I Reset command: @ C E A F W CR (40H 43H 45H 41H 46H 57H 0DH)

The address codes of transducers will be reset to "01" and the buad rate will be reset to 9600bps by the reset command whatever the previous address codes and buad rate of the transducers are. Four bytes of data will be responded from the transducer after receiving the reset command. This command can not be used in the network; otherwise it will cause bus conflict.

I Data Acquisition AD reset command: @ C E A A D CR (40H 43H 45H 41H 41H 44H 0DH)

Please contact your shipper when user needs recalibrate the product. Our technicians will help you to recalibrate by using other internal command.

8 1-phase intelligent electrical isolation transducer MODBUS communication protocol

1 Format of message

(1)Function code 03H--- to read the contents of registers from the slave equipment

The message from the master equipment:

Address of the slave equipment	(01H-FFH	1byte)
Function code	(03H	1byte)
Address of the first register	(2bytes)	
Quantity of registers	(2bytes)	
CRC code	(2bytes)	

The correct responded message from the slave equipment

Address of the slave equipment	(01H-FFH	1byte)
Function code	(03H	1byte)
Byte count	(2xN*	1byte)
Data section	(N*x 2 bytes)	
CRC code	(2bytes)	

(2) Function code 10H---to set data of registers of the slave equipment

The message from the master equipment

Address of the slave equipment	(01H-FFH	1byte)
Function code	(10H	1byte)
Address of the first register	(2bytes)	
Quantity of registers	(2bytes)	
Byte count	(2xN*	1byte)
The data written to the register	(2x N*)	
CRC code	(2bytes)	

The correct responded message from the slave equipment

Address of the slave equipment	(01H-FFH	1byte)
Function code	(10H	1byte)
Address of the first register	(2bytes)	
Quantity of registers	(2bytes)	
CRC code	(2bytes)	

Note: 1 For all address of registers, quantity of registers and contents of registers (data), the high order byte is before their low order byte.

But the low order byte of CRC code is before its high order byte.

2 the length of the register is 16bits (2 bytes).

2Format of commands and explanation of the registers

(1)List of definitions of registers for electrical parameters data:

Address of register	Contents of	Quantity of	Attribute if	Range of data
---------------------	-------------	-------------	--------------	---------------

(Hex)	registers	registers	registers	
000CH	Negative active energy	2	Read only	0 ~7FFFFFFFH
000EH	Negative reactive energy	2	Read only	0 ~7FFFFFFFH
0010H	A phase voltage	1	Read only	0~12000
0011H	A phase current	1	Read only	0~12000
0012H	active power P	1	Read only	-12000~+12000
0013H	reactive power Q	1	Read only	-12000~+12000
0014H	power factor COS	1	Read only	-10000~+10000
0015H	Frequency F	1	Read only	45000~65000
0016H	Positive active energy	2	Read only	0~7FFFFFFFH
0018H	Positive reactive energy	2	Read only	0~7FFFFFFFH

(2) List of definitions of registers for transducer's name, address and baudrate:

Address of register (Hex)	Contents of registers	Quantity of registers	Attribute if registers	Range of data
0020H	Address and Baudrate	1	Read/ write	Address (0-256) Baudrate (03-10)
0021H	Transducer's name	2	Read only	Depend on part number (4bytes)
0023H	Parity check	1	Read/write	0 - no parity; 1 - odd parity; 2 - even parity; 3-2 stop bit, flag bit; 4-2 stop bit, space bit;
0024H	Voltage range	1	Read/write	0-65536(Not involved in the calculation)
0025H	Current range	1	Read/write	0-65536(Not involved in the calculation)

(3) The explanation of register "to clear the data of energy"

Address of register (Hex)	Contents of registers	Quantity of registers	Attribute if registers	Range of data
00A7H	Clear the data of the energy	1	Write	0
00A8H	Broadcast address change	1	Write	1 the broadcast address FAH
00A9H	Reset AD	1	Write	0

(4)Example:

For all address of registers, quantity of registers and contents of registers (data), the high order byte is before their low order byte. But the low order byte of CRC code is before its high order byte.

A: Example of the commands "to read all data"

Address of the slave equipment	Function code	Address of the first register		Quantity of registers		CRC-L	CRC-H
01H	03H	00H	10H	00H	0AH	C4H	08H

Note: 00H is the high order byte of the register, 10H is the low order byte of the register

The data output sequence is shown in the 'Electrical Parameter Data Register Definition Table'

B: Example for the commands “to modify the address and baudrate”:

(Change the address from 01 to 02, set new baudrate to 9600pbs <code 06>)

Address of the slave equipment	Function code	Address of the first register		Quantity of registers		Data bytes count			Data written to register		CRC-L	CRC-H
		00H	20H	00H	01H	02H	02H	06H	20H	52H		
01H	10H	00H	20H	00H	01H	02H	02H	06H	20H	52H		

Note: Code for baudrate setting: 03--1200bps 04--2400bps 05--4800bps 06--9600bps 07--19200bps 08--38400bps

09--57600bps 0A--115200bps; S5 case product can reach 19200bps;

C: Example for the command “to read the transducer’s name and configuration”

Address of the slave equipment	Function code	Address of the first register		Quantity of registers		CRC-L	CRC-H
		00H	20H	00H	03H		
01H	03H	00H	20H	00H	03H	04H	01H

D: Example for the command “to modify the parity mode” (to odd parity mode)

Address of the slave equipment	Function code	Address of the first register		Quantity of registers		Data bytes count			Data written to register		CRC-L	CRC-H
		00H	23H	00H	01H	02H	00H	01H	60H	C3H		
01H	10H	00H	23H	00H	01H	02H	00H	01H	60H	C3H		

E: Example for the command: “to clear the data of energy”

Address of the slave equipment	Function code	Address of the first register		Quantity of registers		Data bytes count			Data written to register		CRC-L	CRC-H
		00H	A7H	00H	01H	02H	00H	00H	BFH	47H		
01H	10H	00H	A7H	00H	01H	02H	00H	00H	BFH	47H		

F: Example for the broadcast command: “to modify the address to 1”

Address of the slave equipment	Function code	Address of the first register		Quantity of registers		Data bytes count			Data written to register		CRC-L	CRC-H
		00H	A8H	00H	01H	02H	00H	01H	09H	4CH		
FAH	10H	00H	A8H	00H	01H	02H	00H	01H	09H	4CH		

3 Data

List of the format of data responded after the read command(suppose the read value of voltage is 380V, the rated value of current is 5A):

NO.	Parameter Name	Input value	Hex date (100%)		1decimal data (100%)	Note
			High byte	Low byte		
1	VA	380V	27	10	10000	True RMS
2	IA	5A	27	10	10000	True RMS
3	P	1900W	27	10	10000	
4	Q	1900Var	27	10	10000	
5	COS Φ	1.0000	27	10	10000	
6	F	50Hz	C3	50	50000	

7	Kwh	1900W/h	4 bytes (high order ahead)		Maximum accumulative is 0x7FFFFFFF	Active energy
---	-----	---------	----------------------------	--	------------------------------------	---------------

8	Varh	1900Var/h	4 bytes (high order ahead)	Maximum accumulative is 0xFFFFFFFF	Reactive energy
---	------	-----------	----------------------------	------------------------------------	-----------------

(1): Format of the data of current, voltage and power

2 bytes sign + data(no sign for AC voltage and AC current)

Range of the data: -12000~+12000

Meaning of the data: 10000 correspond to the rated value. For example, when the maximum value of input current is 5.000A, the expected output value is 10000D or 2710H and 25.000A correspond to 5000D or 1388H of the expected output value.

8-bit low order byte (responed data)

7	6	5	4	3	2	1	LSB
---	---	---	---	---	---	---	-----

8-bit high order byte

Sign 1=negative 0=positive	MSB	13	12	11	10	9	8
----------------------------------	-----	----	----	----	----	---	---

(2) Calculation of power:

$$P = (X_p * (\text{current range} * \text{voltage range})) / 10000 \quad (\text{W})$$

$$Q = (X_q * (\text{current range} * \text{voltage range})) / 10000 \quad (\text{Var})$$

Thereinto: X_p ---the data of active power received by the master equipment. (2 bytes, high order byte ahead, the MSB is sign bit)

X_q ---the data of reactive power received by the master equipment. (2 bytes, high order byte ahead, the MSB is sign bit)

(3) Calculation of active energy

$$N = n * \text{current range} * \text{voltage range} / (1000 * 3600) \quad (\text{kWh})$$

Thereinto: n --- the data of active energy received by the master equipment. (4 bytes, high order byte ahead, the MSB is sign bit)

(4) Calculation of frequency

$$F = f / 1000 \quad (\text{Hz}) \quad \text{When the frequency is greater than 500HZ divided by 100;}$$

Thereinto: F --- the data of frequency received by the master equipment. (2 bytes, high order byte ahead, the MSB is sign bit)

(5): Calculation of current and voltage

$$U = u / 10000 * \text{voltage range} \quad (\text{V})$$

Thereinto: U --- the data of voltage received by the master equipment. (2 bytes, high order byte ahead, the MSB is sign bit)

$$I = i / 10000 * \text{current range} \quad (\text{A})$$

Thereinto: I --- the data of current received by the master equipment. (2 bytes, high order byte ahead, the MSB is sign bit)

Please contact us if you need some internal calibrating commands for zero input calibration.

9 Frequently Asked Questions

No.	Related questions	Instructions and answers
1	Red light state	<ol style="list-style-type: none"> Normally the red light flashes frequency 100mS after power on Red light flashing slowly and flashing frequency is 1.6 seconds or so, the module watchdog reset, site interference or product anomalies. When power on, the red light does not shine and first to test power supply current (normal work 30mA), no work current or a large current, the power supply is abnormal.
2	Green light state	<ol style="list-style-type: none"> When the communication is normal, the green light will be on from the start of receiving first byte to end of sending the last byte (about 1ms for 96-bit communication). When green light quickly turn and off (micro-bright), there is a wrong with communication address, baud rate or commands, and the serial port is frequently interrupted exit.

		3 Sending a command without any flashing of the green light, the communication circuit or wiring is error, the hardware line nowhere.
3	Current signal wiring	1 The current input should be connected correctly according to the direction shown in the wiring diagram. The current direction should be input from the reverse side of the wiring diagram. 2When the current wiring direction is reversed, the active power output is negative.
4	Test software	1 If running the software without the "*.ocx" file, please run the installation software on the CD-ROM or download the plug-in from www.sset.cn/tech_down.htm to run the installation program. 2Test software is for the ASCII protocol and MODBUS protocol, please select according to the product model. Running the software after searching the module and select the searched module, Click the Tools menu to modify the address and baud rate.
5	The power value read on the PLC or the touch screen is negative or the power value is greater than 32768	This product uses the most significant bit for the sign bit, as defined in the device is a signed integer data, So the definition of the register data type in the PLC should be unsigned integer data. When the data is greater than 32768, the value of this time represents a negative value, must be recalculated with the sign bit out in the software.
6	Energy accumulation time	With 8-byte data, the cumulative time of energy measurement is more than 10 years.